

■Standard specifications

Item		Specification												
Applicable motor (kW)		0.4	0.75	1.5	2.2	3.7	5.5	7.5	11	15	18.5	22	30	
Machine type	Input voltage class	VF-FS1												
	3-phase 200V class	VFFS1-	2004PM	2007PM	2015PM	2022PM	2037PM	2055PM	2075PM	2110PM	2150PM	2185PM	2220PM	2300PM
	3-phase 400V class	VFFS1-	4004PL	4007PL	4015PL	4022PL	4037PL	4055PL	4075PL	4110PL	4150PL	4185PL	4220PL	4300PL
Rating	Capacity (kVA)	200V class/400V class	1.1	1.8/1.6	2.9/2.8	4.0/3.9	6.7/6.9	9.2/9.1	12.2	17.6/17.1	23.2	28.5/28.2	33.5/33.2	44.6
	Output current (A)	3-phase 200V class	2.8	4.6	7.5	10.6	17.5	24.2	32	46.2	61	74.8(67.3)	88(79.2)	117.0(105.3)
		3-phase 400V class	1.4	2.2	3.7	5.1	9.1	12	16	22.5	30.5	37(33.3)	43.5(39.2)	58.5(52.7)
Power supply	Voltage/frequency	200V class: 200V to 240V - 50/60Hz, 400V class: 3-phase 380 to 480V - 50/60Hz												
	Tolerance	Voltage +10%, -15% (±10% when the inverter is used continuously (load of 100%))												
	Output voltage adjustment	Adjustable within a range of the corrected supply voltage 50 to 660V (Unadjustable to any voltage higher than the input voltage).												
	Output frequency range	0.5 to 200.0Hz (default setting 0.5 to 80.0Hz)												
	Voltage/frequency characteristics	V/f constant, variable torque, automatic torque boost, vector control, automatic energy conservation, PM motor control, auto-tuning function												
	Overload current rating	60 seconds at 110%, 2 seconds at 180% (Anti-time limit characteristic)												
	Main functions	Wizard, Local/Remote change-over, Bumpless operation, Forced fire-speed control, PTC thermal protection, Programmable I/O terminal block, Auto-restart												
	Ambient temperature/Relative humidity	-10 to 60°C (Current decrease when over 40°C) /20 to 93% free from condensation and vapor												
	Protective method	0.4 to 18.5kW : IP20 enclosed type(JEM1030), 22kW and over : IP00 type(JEM1030)												
	Cooling method	Forced air cooling												
	Built-in filter	3-phase 200V class: basic noise filter, 400V class:EMI noise filter (IEC/EN61800-3, 1st Environment.C2 or IEC/EN61800-3, 2nd Environment.C3)												

The rated output current in the parenthesis is at 12kHz of PWM carrier frequency(F300)setting.

■Exterior dimensions and weight

Input voltage Class	Applicable motor(kW)	Inverter model	Dimensions(mm)			Approximate weight(kg)
			Width	Height	Depth	
3-phase 200V (IP20/IP00)	0.4	VFFS1-2004PM	105	130	150	1.2
	0.75	VFFS1-2007PM	105	130	150	1.2
	1.5	VFFS1-2015PM	105	130	150	1.2
	2.2	VFFS1-2022PM	105	130	150	1.2
	3.7	VFFS1-2037PM	140	170	150	2.1
	5.5	VFFS1-2055PM	180	220	170	4.3
	7.5	VFFS1-2075PM	180	220	170	4.3
	11	VFFS1-2110PM	245	310	190	8.6
	15	VFFS1-2150PM	245	310	190	8.6
	18.5	VFFS1-2185PM	245	310	190	8.9
3-phase 400V (IP20/IP00)	0.4	VFFS1-4004PL	105	130	150	1.4
	0.75	VFFS1-4007PL	105	130	150	1.4
	1.5	VFFS1-4015PL	105	130	150	1.4
	2.2	VFFS1-4022PL	105	130	150	1.4
	3.7	VFFS1-4037PL	140	170	150	2.4
	5.5	VFFS1-4055PL	140	170	150	2.4
	7.5	VFFS1-4075PL	180	220	170	4.7
	11	VFFS1-4110PL	180	220	170	4.7
	15	VFFS1-4150PL	245	310	190	9
	18.5	VFFS1-4185PL	245	310	190	9
	22	VFFS1-4220PL	240	420	214	15.4
	30	VFFS1-4300PL	240	420	214	15.4

※2:Coming soon

■Standard connection diagram : Sink logic(common : cc)

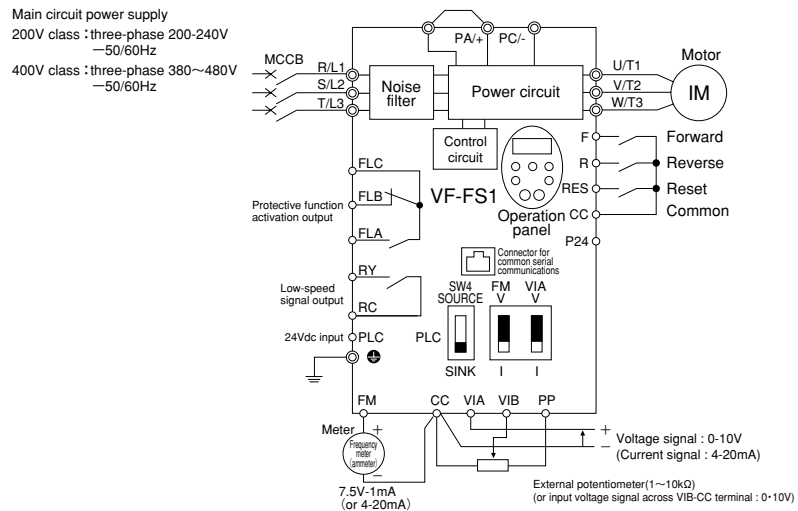

■Standard connection diagram : Source logic(common : P24)

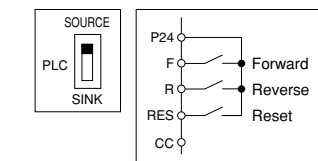

To users of our inverters : Our inverters are designed to control the speeds of three-phase induction motors for general industry.

⚠ Precautions

- Read the instruction manual before installing or operating the inverter unit and store it in a safe place for reference.
- When using our inverters for equipment such as nuclear power control, aviation and space flight control, traffic, and safety, and there is a risk that any failure or malfunction of the inverter could directly endanger human life or cause injury, please contact our headquarters, branch, or office printed on the front and back covers of this catalogue. Special precautions must be taken and such applications must be studied carefully.
- When using our inverters for critical equipment, even though the inverters are manufactured under strict quality control always fit your equipment with safety devices to prevent serious accident or loss should the inverter fail (such as issuing an inverter failure signal).
- Do not use our inverters for any load other than three-phase induction motors.
- None of Toshiba, its subsidiaries, affiliates or agents, shall be liable for any physical damages, including, without limitation, malfunction, anomaly, breakdown or any other problem that may occur in any apparatus in which the Toshiba inverter is incorporated or to any equipment that is used in combination with the Toshiba inverter. Nor shall Toshiba, its subsidiaries, affiliates or agents be liable for any compensatory damages resulting from such utilization, including compensation for special, indirect, incidental, consequential, punitive or exemplary damages, or for loss of profit, income or data, even if the user has been advised or apprised of the likelihood of the occurrence of such

For further information, please contact your nearest Toshiba Representative or International Operations-Producer Goods.
 The information in this brochure is subject to change without notice.

TOSHIBA

TOSHIBA CORPORATION
 INDUSTRIAL AND POWER SYSTEMS & SERVICES COMPANY

Overseas Sales & Marketing Department
 Electrical Apparatus & Measurement Division
 1-1,Shibaura 1-chome, Minato-ku,
 Tokyo 105-8001,Japan
 Tel.: +81(0)3-3457-4911 Fax.: +81(0)3-5444-9268

06-01 (AB)8697 (AB)

Printed in Japan

TOSHIBA

Transistor Inverter

TOSVERT™ inverter dedicated to fan and pump for HVAC

VF-FS1

Three-phase 200V class 0.4kW to 30kW
 Three-phase 400V class 0.4kW to 30kW



DREAM INVERTER dedicated to fan and pump for HVAC

SPACE SAVING, ECO-FRIENDLY, NOISE-LESS and LONG LIFE
The VF-FS1 provides these features as standard.



- Applications:
- AHUs
 - Ventilation fans
 - Chillers
 - Water pumps etc.



TOSVERT™ inverter dedicated to fan and pump for HVAC

VF-FS1

Voltage class	Applicable Motor Output (kW)										
	0.4	0.75	1.5	2.2	3.7	5.5	7.5	11	15	18.5	22
3-phase 200V class (IP20/IP00)	[Color-coded bar]										
3-phase 400V class (IP20/IP00)	[Color-coded bar]										
3-phase 400V class (IP54)	[Color-coded bar]										

Note: VF-FS1 is not applicable for apparatus which needs sudden deceleration and stop.



POINT 1 Half installation space and less wiring

Reactor-less harmonic suppress technologies and built-in filter*1 reduce 50% of installation space, save time and cost of wiring.

*1 400V class models, EMI noise filter built-in as standard model (European EMC Directive, IEC/EN618000-3, 1st Environment, C2 or IEC/EN61800-3, 2nd Environment, C3)
200V class models, Basic noise filter built-in as standard model

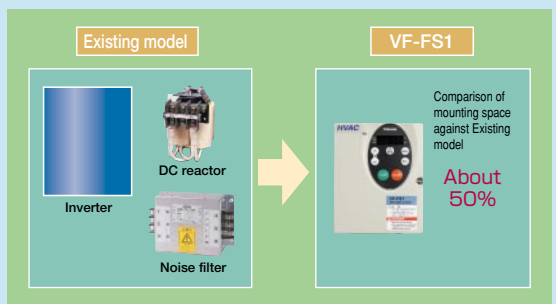

POINT 2 Reactor-less harmonic reduction

Toshiba unique technologies suppress harmonics, particularly 5th and 7th harmonic current that affect power sources. And the power factor in all models has been improved. Harmonics are controlled to within the Total Harmonic Distortion (THD) of international standard IEC61000-3-12 without any external reactor. (Rsc ≥ 120)

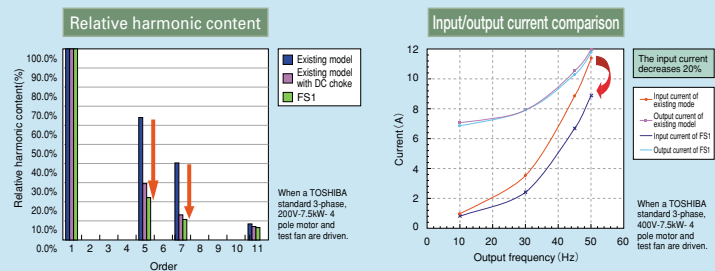

POINT 3 Long life and easy maintenance

- 15 years life designed main capacitors
- An alarm warns when the main circuit capacitors, circuit boards capacitors, or cooling fan needs to be replaced.
- Cooling fan's On/Off control extend its life
- Easy replacement by one touch
- The inverter unit can be replaced by removable terminal block without disconnecting cables.

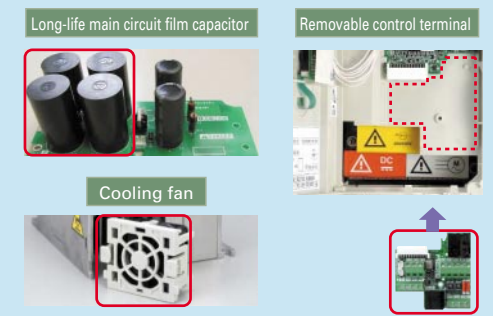

POINT 4 Special softwares for fan and pump application are built-in

- Ideal functions are built-in for fan and pump application.
- The local or remote operation can be selected by one touch
 - Bumpless function realize seamless operation between local and remote
 - Fire control enables forced operation in emergency
 - Speed reference can manage on/off operation (Sleep function)
 - Low current detection can notice a broken belt or low load for pump application
 - PTC thermistor input
 - Include RS485 (TOSHIBA/Modbus protocol) communication as standard
 - Optional filed buses for LonWorks®, BACnet®, Metasys®N2 and Siemens APOGEE™ FLN as built in option.

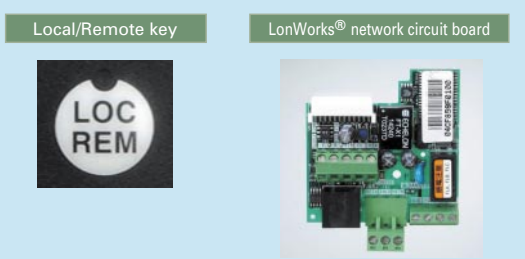

POINT 5 More energy saving and easier operation

The advanced energy-saving mode optimizes fan and pump efficiency even at normally inefficient in low speeds. The effect can be monitored by operation panel or through serial communication data. A wizard function enable set the 10 most often used parameter quickly.

Quick setting wizard

Title	Function
RL1	Automatic acceleration/deceleration
ACC	Acceleration time 1
dEC	Deceleration time 1
LL	Lower limit frequency
UL	Upper limit frequency
tHr	Motor thermal protection
Fa	Meter adjustment
PE	V/F control mode selection
uL	Base frequency 1
uLv	Base frequency voltage 1

