

Linear Measuring Technology

Draw wire mechanics with encoder or analogue sensor

Draw wire encoder C120

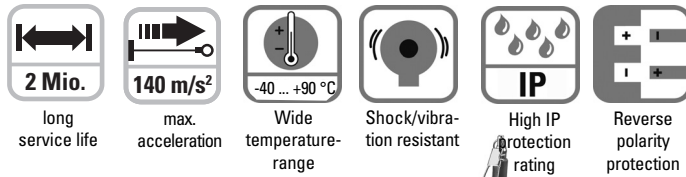

Robust

- **Insensitive to the environment**
Titanium-anodised aluminium housing
- **High-resistance wire**
Stainless steel wire
- **Wire exit free from wear**
Diamond-polished ceramic guide
- **Can be used in a wide temperature range without extra charge**
max. -40 +90 °C



Versatile

- **Suitable for various sensors/encoders**
 - Absolute
 - Fieldbus
 - Incremental
 - Analogue
- **Quick mounting**
Fastening by means of 2 screws
- **Flexible connection possibilities**
Cable, connector, radial, axial
- **Linearity up to 0.05 %**

Dynamic

- **High traverse speed**
- **High acceleration**
Dynamic spring traction by means of a constant force spring, long service life, approx. 2 million complete cycles

Mechanical characteristics (draw wire mechanics):

Measuring range:	6000 mm
Extension force F _{min} :	5.4 N
F _{max} :	7.8 N
Max. speed:	10 m/s
Max. acceleration:	140 m/s ²
Linearity:	analogue output: 0.1 % (of the measuring range) encoder: 0.05 % (of the measuring range)
Weight:	approx. 1600 g (depending on the sensor/encoder used)
Materials:	housing: titanium-anodised aluminium wire: stainless steel ø 0.5 mm
Protection (sensor):	IP65 (IP67 on request for encoders)
Lifetime	> 2 million full cycles

Operating principle:

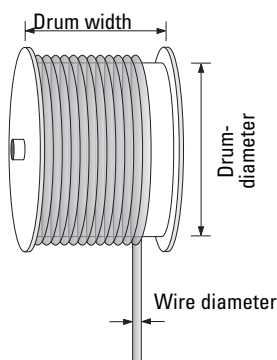

Construction:

The core of a draw wire device is a drum mounted on bearings, onto which a wire is wound. Winding takes place via a spring-loaded device.

Note

Exceeding the maximum extension length of the draw wire will lead to damage to the wire and the mechanics.

Linear Measuring Technology

Draw wire mechanics with encoder or analogue sensor



Draw wire encoder C120

Electrical characteristics (digital output):

The electrical characteristics of the draw wire mechanics with digital output can be found in the data sheets of the encoders.

Electrical characteristics (analogue output):

Analogue output:	0 ... 10 V	4 ... 20 mA	Potentiometer
Output:	0 ... 10 V galvanically isolated, 4 conductors	4 ... 20 mA 2 conductors	1 kOhm
Supply voltage:	12 ... 30 V DC	12 ... 30 V DC	max. 30 V DC
Recommended slider current:	–	–	< 1 µA
Max. current consumption:	22.5 mA (no load)	50 mA	–
Reverse polarity protection:	yes	yes	–
Operating temperature:	-20 ... +60 °C	-20 ... +60 °C	-20 ... +85 °C

Connection diagrams:

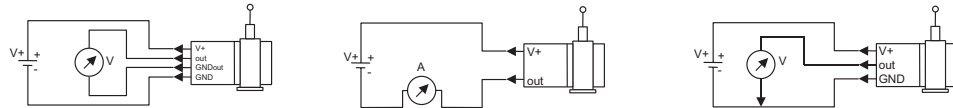

CE compliant according to: EN 61000-6-1, EN 61000-6-4, EN 61000-6-3

Terminal assignment (analogue output):

Pin	Cable colour	0 ... 10 V	4 ... 20 mA	1 kOhm
1	brown	V+	V+	V+
2	white	Signal	n. c.	Slider
3	blue	GND	Signal	GND
4	black	GND Sig.	n. c.	n. c.

Connector (analogue output):

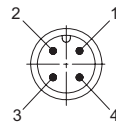

Dimensions:

Draw wire mechanics with encoder

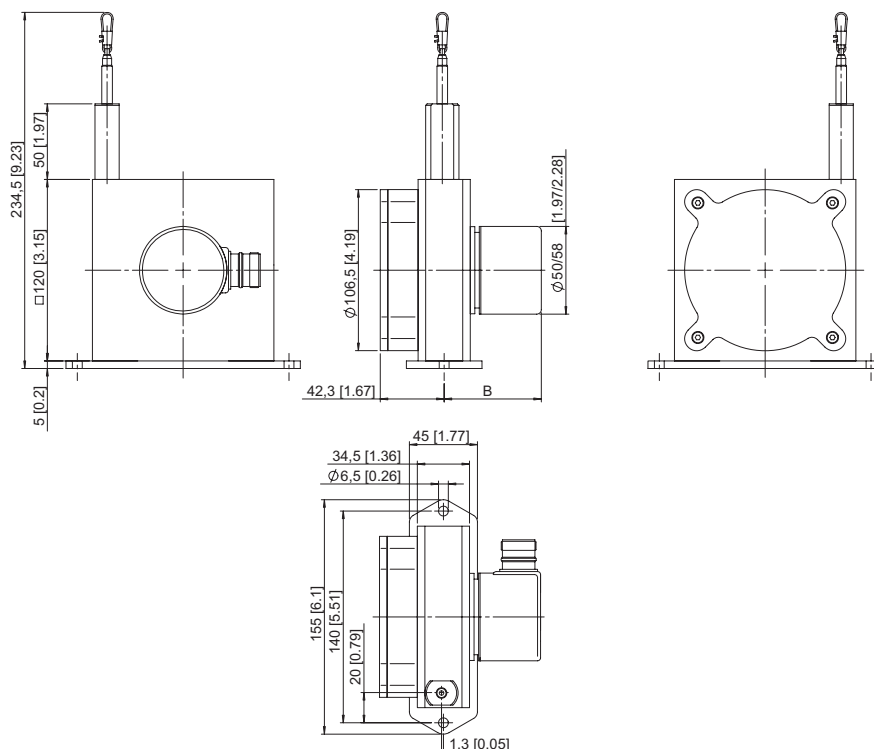

Dimension B depends on the encoder used	
Encoder	B
Sendix incremental (5000) D8.4B1.XXXX. 00 XX.XXXX	54.25
Sendix absolut (5863) D8.4B1.XXXX. 63 XX.XXXX	66.75
Sendix absolut (5868) D8.4B1.XXXX. 68 XX.XXX	93.25

Linear Measuring Technology

Draw wire mechanics with encoder or analogue sensor

Draw wire encoder C120

Order code with encoder:

D8.4C1.XXXX.XXXX.XXXX

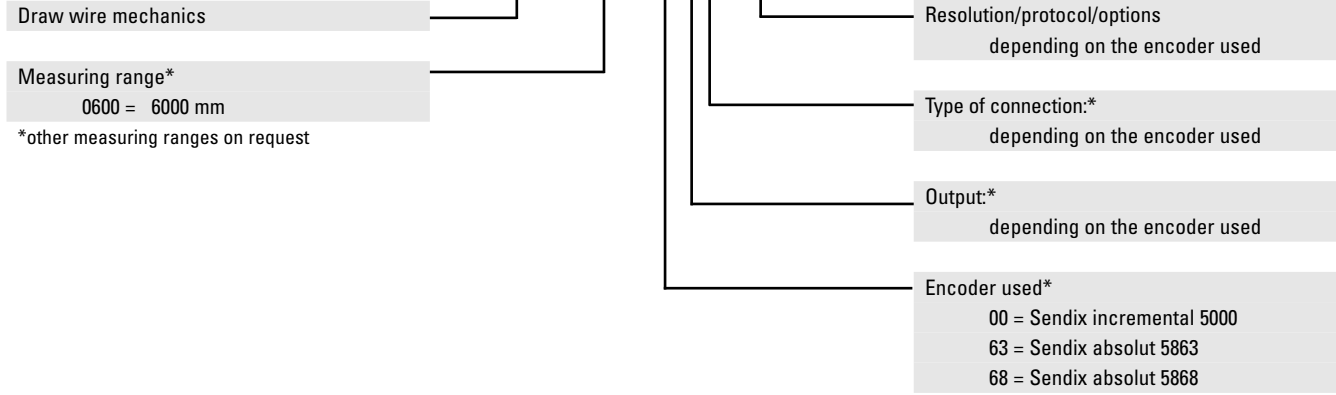

*You will find our recommended encoders below

Standard resolutions for draw wire with incremental encoder Sendix 5000, drum circumference 317.68 mm		
Pulses/revolution	500	2000
Pulses/mm	1.6	6.3
Resolution [mm]	~0.63	~0.16

Standard resolutions for draw wire with absolute encoder Sendix 5863 or 5868, drum circumference 317.68 mm		
Absolute encoder	5863	5868
Pulses/revolution	2048/ 11 bits	4096, programmable via the bus/ 12 bits
Pulses/mm	6.4	12.9
Resolution [mm]	~0.16	~0.08

Recommended standard device
with **incremental** encoder
Sendix 5000:

D8.4C1.XXXX.0053.2000

The standard device is supplied mounted. The mounted encoder is the Sendix incremental 5000 encoder, Connector axial 8 pin M12, Push-pull with inverted signals, supply voltage 10 ... 30 V DC (8.5000.8353.2000)

Recommended standard device
with **absolute** encoder
Sendix 5863 or 5868:

D8.4C1.XXXX.6324.G123

Sendix absolut 5863 encoder with **SSI interface** (Gray code), 2048 pulses/rev., Set key, 10 ... 30 V DC, radial 12 pole M23 connector (8.5863.1224.G123)

D8.4C1.XXXX.6822.2113

Sendix absolut 5868 encoder with **CANopen interface**, 4096 pulses/rev. programmable via the bus, Set key, 10 ... 30 V DC, M12 connector (8.5868.1222.2113)

D8.4C1.XXXX.6832.3113

Sendix absolut 5868 encoder with **Profibus connection**, 4096 pulses/rev. programmable via the bus, Set key, 10 ... 30 V DC, M12 connector (8.5868.1232.3113)

Measuring range
0600 = 6000 mm
*other measuring ranges on request

Linear Measuring Technology

Draw wire mechanics with encoder or analogue sensor



Draw wire encoder C120

Dimensions:

Draw wire mechanics with analogue sensor

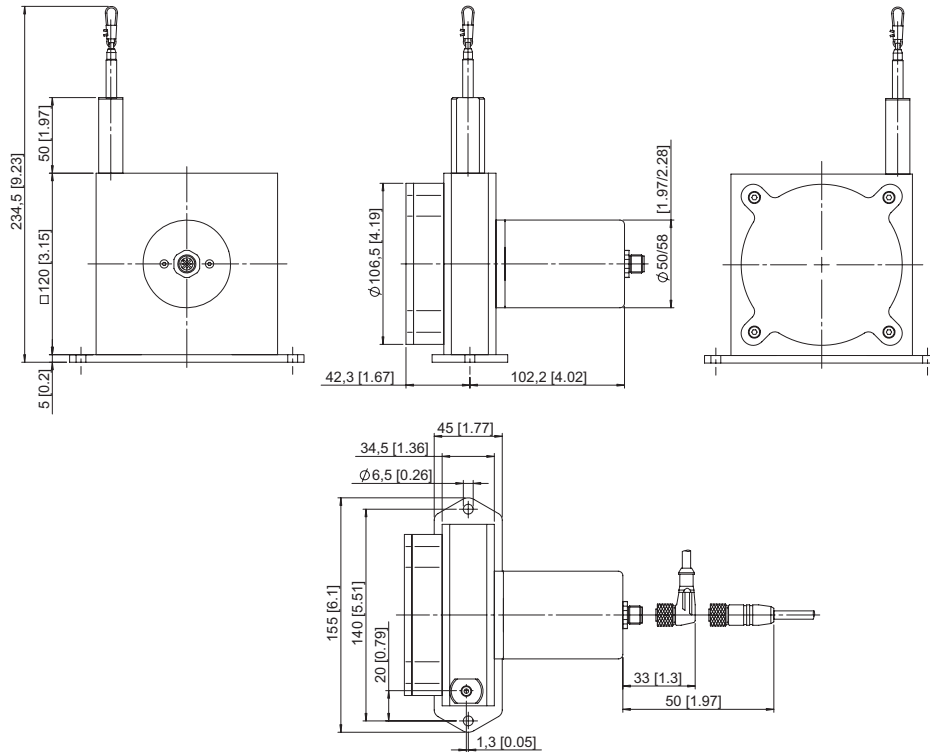

Order code with analogue sensor:

D8.3C1.XXXX.XXXX.0000

Draw wire mechanics

Measuring range*

0600 = 6000 mm

*other measuring ranges on request

Type of connection:

1 = Axial cable, length 2m

3 = 4-pole M12 connector

Analogue sensor output

A11 = 4 ... 20 mA

Supply voltage 12 ... 30 V DC

A22 = 0 ... 10 V

Supply voltage 12 ... 30 V DC

A33 = Potentiometer 1 kOhm

Max. supply voltage 30 V DC

Accessories

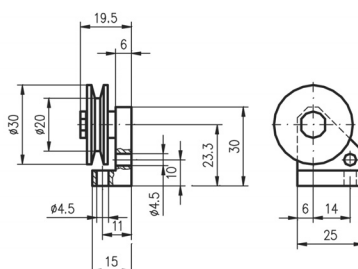

- Guide pulley for draw-wire encoder
Order code 8.0000.7000.0031